



# IC Live X Series User's Manual

Digitally Steerable Line Array Loudspeaker Systems



## IMPORTANT SAFETY INSTRUCTIONS

1. Read these instructions.
  2. Keep these instructions.
  3. Heed all warnings.
  4. Follow all instructions
  5. Do not use this apparatus near water. The apparatus shall not be exposed to dripping or splashing and no objects filled with liquids, such as vases, shall be placed on it.
  6. Clean only with dry cloth.
  7. Do not block any ventilation openings. Install in accordance with the manufacturer's instructions.
  8. Do not install near any heat sources such as radiators, heat registers, stoves, or other apparatus (including amplifiers) that produce heat.
  9. Do not defeat the safety purpose of the polarized or grounding-type plug. A polarized plug has two blades with one wider than the other. A grounding type plug has two blades and a third grounding prong. The wide blade or the third prong is provided for your safety. If the provided plug does not fit into your outlet, consult an electrician for replacement of the obsolete outlet.
  10. Protect the power cord from being walked on or pinched particularly at plugs, convenience receptacles, and the point where they exit from the apparatus.
11. Make sure the power cord remains readily accessible at all times.
  12. The AC Power Cord is the AC Mains disconnect.
  13. Only use attachments/accessories specified by the manufacturer.
  14. Disconnect this apparatus during lightning storms or when unused for long periods of time.
  15. Refer all servicing to qualified service personnel. Servicing is required when the apparatus has been damaged in any way, such as power-supply cord or plug is damaged, liquid has been spilled or objects have fallen into the apparatus, the apparatus has been exposed to rain or moisture, does not operate normally, or has been dropped.

**“WARNING - TO REDUCE THE RISK OF FIRE OR ELECTRIC SHOCK, DO NOT EXPOSE THIS APPARATUS TO RAIN OR MOISTURE”**

**“CAUTION: THESE SERVICING INSTRUCTIONS ARE FOR USE BY QUALIFIED SERVICE PERSONNEL ONLY. TO REDUCE THE RISK OF ELECTRIC SHOCK DO NOT PERFORM ANY SERVICING OTHER THAN THAT CONTAINED IN THE OPERATING INSTRUCTIONS UNLESS YOU ARE QUALIFIED TO DO SO”.**

Explanation of Graphical Symbols



The lightning flash with arrowhead symbol, within an equilateral triangle, is intended to alert the user to the presence of uninsulated "Dangerous Voltage" within the product's enclosure that may be of sufficient magnitude to constitute a risk of electric shock to humans.



The exclamation point, within an equilateral presence of important operating and maintenance (servicing) instructions in the literature accompanying the product.

Erklärung der graphischen Symbole



Der Blitz mit nach untenzielendem Pfeil in einem gleichseitigen Dreieck weist den Benutzer auf das Vorhandensein einer unisolierten, "gefährlichen Spannung" im Gehäuse hin, die stark genug sein kann, einer Person einen gefährlichen elektrischen Schlag zu versetzen.



Das Ausrufezeichen in einem gleichseitigen Dreieck weist den Benutzer auf wichtige Betriebs- und Wartungsvorschriften in den beiliegenden Unterlagen des Gerätes hin.

**CAUTION**

**RISK OF ELECTRONIC SHOCK:  
OPEN ONLY IF QUALIFIED AS  
SERVICE PERSONNEL**

**VORSICHT**

**GEFAHR EINES ELEKTRISCHEN SCHLAGES:  
NUR VON QUALIFIZIEREM WARTUNGSPERSONAL  
ZU ÖFFNEN**

To reiterate the above warnings: servicing instructions are for use by qualified personnel only. To avoid electric shock, do not perform any servicing other than that contained in the Operation Instructions unless you are qualified to do so. Refer all servicing to qualified personnel.

Eindringliche Warnung: Wartungsvorschriften dienen nur der Benutzung durch qualifiziertes Personal. Zur Vermeidung eines elektrischen Schlages keine anderen als die in den Betriebsvorschriften beschriebenen Wartungsarbeiten ausführen, es sei denn Sie sind dafür qualifiziert. Wartungsarbeiten auszuführen.

### IMPORTANT

**Your Iconyx Steerable Column Loudspeaker contains no user-serviceable parts,  
all service should be referred to qualified service personnel.**

## IMPORTANT WEATHER RESISTANT SAFETY INSTRUCTIONS

1. Read these instructions.
2. Keep these instructions.
3. Heed all warnings.
4. Follow all instructions
5. Clean only with dry cloth.
6. Do not block any ventilation openings. Install in accordance with the manufacturer's instructions.
7. Do not install near any heat sources such as radiators, heat registers, stoves, or other apparatus (including amplifiers) that produce heat.
8. Means of disconnection of the unit from the AC mains shall be specified, including the electrical ratings of the disconnect device.
9. Only use attachments/accessories specified by the manufacturer.
10. Disconnect this apparatus during lightning storms or when unused for long periods of time.
11. Install all cabling or conduit with drip loops to prevent water wicking.
12. Refer all servicing to qualified service personnel. Servicing is required when the apparatus has been damaged in any way, such as power-supply cord or plug is damaged, liquid has been spilled or objects have fallen into the apparatus, the interior of the apparatus has been exposed to rain or moisture, does not operate normally, or has been dropped.

**THE INSTALLATION SHALL BE CARRIED OUT IN ACCORDANCE WITH ALL APPLICABLE INSTALLATION RULES IN COMPLIANCE WITH THE NATIONAL ELECTRICAL CODE, ANSI/NFPA 70 AND CANADIAN ELECTRICAL CODE PART I.**

**“CAUTION: THESE SERVICING INSTRUCTIONS ARE FOR USE BY QUALIFIED SERVICE PERSONNEL ONLY. TO REDUCE THE RISK OF ELECTRIC SHOCK DO NOT PERFORM ANY SERVICING OTHER THAN THAT CONTAINED IN THE OPERATING INSTRUCTIONS UNLESS YOU ARE QUALIFIED TO DO SO”.**

Explanation of Graphical Symbols



The lightning flash with arrowhead symbol, within an equilateral triangle, is intended to alert the user to the presence of uninsulated "Dangerous Voltage" within the product's enclosure that may be of sufficient magnitude to constitute a risk of electric shock to humans.



The exclamation point, within an equilateral presence of important operating and maintenance (servicing) instructions in the literature accompanying the product.

Erklärung der graphischen Symbole



Der Blitz mit nach untenzielendem Pfeil in einem gleichseitigen Dreieck weist den Benutzer auf das Vorhandensein einer unisolierten, "gefährlichen Spannung" im Gehäuse hin, die stark genug sein kann, einer Person einen gefährlichen elektrischen Schlag zu versetzen.



Das Ausrufezeichen in einem gleichseitigen Dreieck weist den Benutzer auf wichtige Betriebs- und Wartungsvorschriften in den beiliegenden Unterlagen des Gerätes hin.

**CAUTION**

**RISK OF ELECTRONIC SHOCK:  
OPEN ONLY IF QUALIFIED AS  
SERVICE PERSONNEL**

**VORSICHT**

**GEFAHR EINES ELEKTRISCHEN SCHLAGES:  
NUR VON QUALIFIZIEREM WARTUNGSPERSONAL  
ZU ÖFFNEN**

To reiterate the above warnings: servicing instructions are for use by qualified personnel only. To avoid electric shock, do not perform any servicing other than that contained in the Operation Instructions unless you are qualified to do so. Refer all servicing to qualified personnel.

Eindringliche Warnung: Wartungsvorschriften dienen nur der Benutzung durch qualifiziertes Personal. Zur Vermeidung eines elektrischen Schlages keine anderen als die in den Betriebsvorschriften beschriebenen Wartungsarbeiten ausführen, es sei denn Sie sind dafür qualifiziert. Wartungsarbeiten auszuführen.

### IMPORTANT

**Your Iconyx Steerable Column Loudspeaker contains no user-serviceable parts,  
all service should be referred to qualified service personnel.**

## Contents

Models covered in this manual:	4
Introduction	5
General Information	5
ICLive X versions and models	6
Understanding ICLive X series model numbers	6
Mobile Version Connections	7
Fixed Install Connections	8
Dante -RD units	8
Amplifier Control Panel	9
Array Assembly	10
Ground Stacking	11
Hinge Kit Brackets	12
Hinge Kit Guidelines and Instructions	12
Wall Mounting	13
Array Interconnections	14
Mobile Unit Interconnections	14
Fixed Install Interconnections	15
Interconnecting -RN units	15
Interconnecting -RD units	16
Interconnecting -RD units with a redundant network	17
Designing and Beam steering ICLive X Arrays	18
Array Guidelines	18
RHAON & Beam steering Workflow	19
ICLive X Beam steering	20
U.R.G.O Beam Steering	20
U.R.G.O. Workflow	21
U.R.G.O. Refinements	23

### Models covered in this manual:

ICLX-RN-BK	ICLXL-RN-BK	ICLLX-RN-BK	ICLX-RN-BK-WR	ICLXL-RN-BK-WR	ICLLX-RN-BK-WR
ICLX-RN-WT	ICLXL-RN-WT	ICLLX-RN-WT	ICLX-RN-WT-WR	ICLXL-RN-WT-WR	ICLLX-RN-WT-WR
ICLX-RN-CC	ICLXL-RN-CC	ICLLX-RN-CC	ICLX-RN-CC-WR	ICLXL-RN-CC-WR	ICLLX-RN-CC-WR
ICLX-RD-BK	ICLXL-RD-BK	ICLLX-RD-BK	ICLX-RD-BK-WR	ICLXL-RD-BK-WR	ICLLX-RD-BK-WR
ICLX-RD-WT	ICLXL-RD-WT	ICLLX-RD-WT	ICLX-RD-WT-WR	ICLXL-RD-WT-WR	ICLLX-RD-WT-WR
ICLX-RD-CC	ICLXL-RD-CC	ICLLX-RD-CC	ICLX-RD-CC-WR	ICLXL-RD-CC-WR	ICLLX-RD-CC-WR



### Introduction

Congratulations on your purchase of a Renkus-Heinz ICLX Series Digitally Steerable Loudspeaker. Your Renkus-Heinz loudspeaker has been designed to provide years of trouble-free, high performance operation. We hope you enjoy it.

Your Renkus-Heinz loudspeaker was completely tested and inspected before leaving our factory and should have arrived in perfect condition. Please carefully inspect your loudspeaker and its shipping carton for any noticeable damage, and if any damage is found, immediately notify the shipping company.

Only the consignee may institute a claim with the carrier for any damage incurred during shipping. Be sure to save the carton and all packing materials for the carrier's inspection.

Important:

*Your Renkus-Heinz loudspeaker and its built-in amplifier contain no user-serviceable parts and all service should be referred to qualified service personnel. We recommend that it be returned to the factory in its original packing carton if factory service is required.*

### General Information

The IC Live X system is a flexible, digitally steerable array system composed of three array modules and two companion subwoofers. The basic building-block module is

the ICLX. IC Live X arrays are composed of multiple ICLX cabinets, up to 12 tall, and the ICLX is the unit of length for IC Live X arrays. The ICLXL and ICLLX are single modules that are two-units tall.

The ICLXL and ICLLX can be used individually as stand alone arrays, or they can be used to extend the height of an array at the bottom—ICLXL—or top—ICLLX—of an array of ICLXs. By convention when describing IC Live X arrays, the unit of length is the number of ICLX cabinets that represent the length of the array, even if some of the cabinets in the array are the two-unit tall ICLXL or ICLLX cabinets.

The illustration below shows the four options for creating a four unit tall IC Live X array using various combinations of ICLX, ICLXL and ICLLX modules.

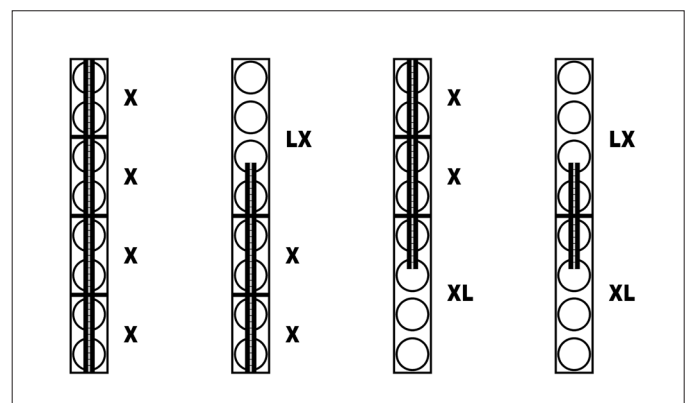

## ICLive X versions and models

IC Live X modules are available in either Fixed or Mobile versions. The versions have different input configurations optimized for use in their respective applications.

Fixed versions are optimized for use in permanently installed applications and feature Phoenix, RJ45, and powerCON connections for cost effective and reliable installation.

Mobile versions have XLR, etherCON, and powerCON TRUE1 looping connectors for rugged, secure connections and fast array building in mobile applications.

Both fixed and mobile versions of the loudspeakers are available in –RN and –RD versions.

The –RN models have Ethernet networked amplifiers controlled and beam steered with RHAON II software. All –RN models have the following features:

- Analog audio inputs (Fixed versions have two analog inputs, mobile versions, one.)
- AES-3 audio inputs. (Fixed versions have two AES-3 inputs, mobile versions, one.)
- Ethernet/RHAON II network connection
- RHAON II beam steering
- Onboard DSP featuring:
  - Eight-band fully parametric EQ

- Parametric high and low shelf
- Parametric high and low pass filters.
- User delay up to 358 ms.
- Nine user savable presets recallable from the back panel or RHAON II.

The –RD models add the following features:

- Dante digital audio input
- Looping or Dante Redundant networking
- Remote control via Crestron

## Understanding ICLive X series model numbers

ICLive X model numbers are descriptive, here's how to understand them:

- ICLX: the basic model
- –RN: RHAON II networked
- –RD: Dante equipped
- –BK: Black
- –WT: White
- –CC: Custom paint color
- –WR: Weather resistant

An **ICLXL-RD-CC-WR** is an ICLXL with Dante, custom color and weather resistant.

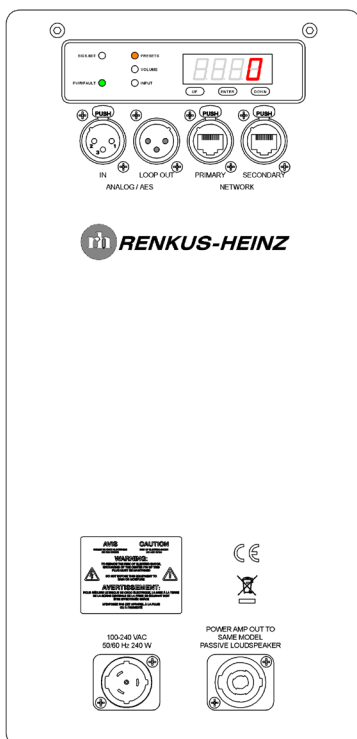

Mobile Version Input Panel

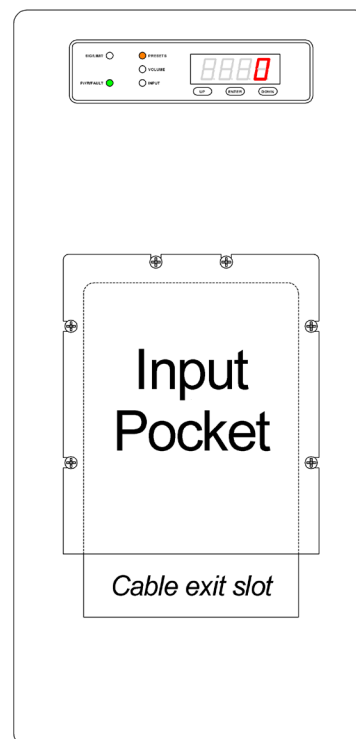

Fixed Version Input Panel



## Mobile Version Connections

All connections on the mobile version are made on the back panel of the loudspeaker

- Analog/AES Input on male XLR connector. Analog and AES-3 digital audio inputs share this connector. Input selection from the control panel or in RHAON II. Use 110 ohm digital audio cable for AES connections, this is recommended for analog connections as well.
- Analog AES Loop Out on female XLR connector. In Analog mode, this is a paralleled loop out. In AES mode, it is a buffered and re-driven loop out. Use 110 ohm digital audio cable for AES connections, this is recommended for analog connections as well.
- Primary Ethernet/RHAON II/Dante connection on an etherCON connection. Standard RJ45 CAT5e or CAT6 patch cables may be used, etherCON shell is recommended for all mobile applications.
- Secondary Ethernet/RHAON II/Dante connection on an etherCON connection. Standard RJ45 CAT5e or CAT6 patch cables may be used, etherCON shell is recommended for all mobile applications. This connection is normally used as a switched, “looping” connector for connecting arrays. On Dante units it may be used instead as a redundant, fail-over, Ethernet network connection. Selection of this is done in Dante Controller software.
- AC Mains Power on Neutrik powerCON TRUE1 Top female connector. Input voltage 100-240 volts, 50/60 Hz., auto-switching.
- AC Mains Power Loop Out on Neutrik powerCON TRUE1 Top male connector.

*For connections to other mobile cabinets in an array, see the array connections section on pg. 14.*

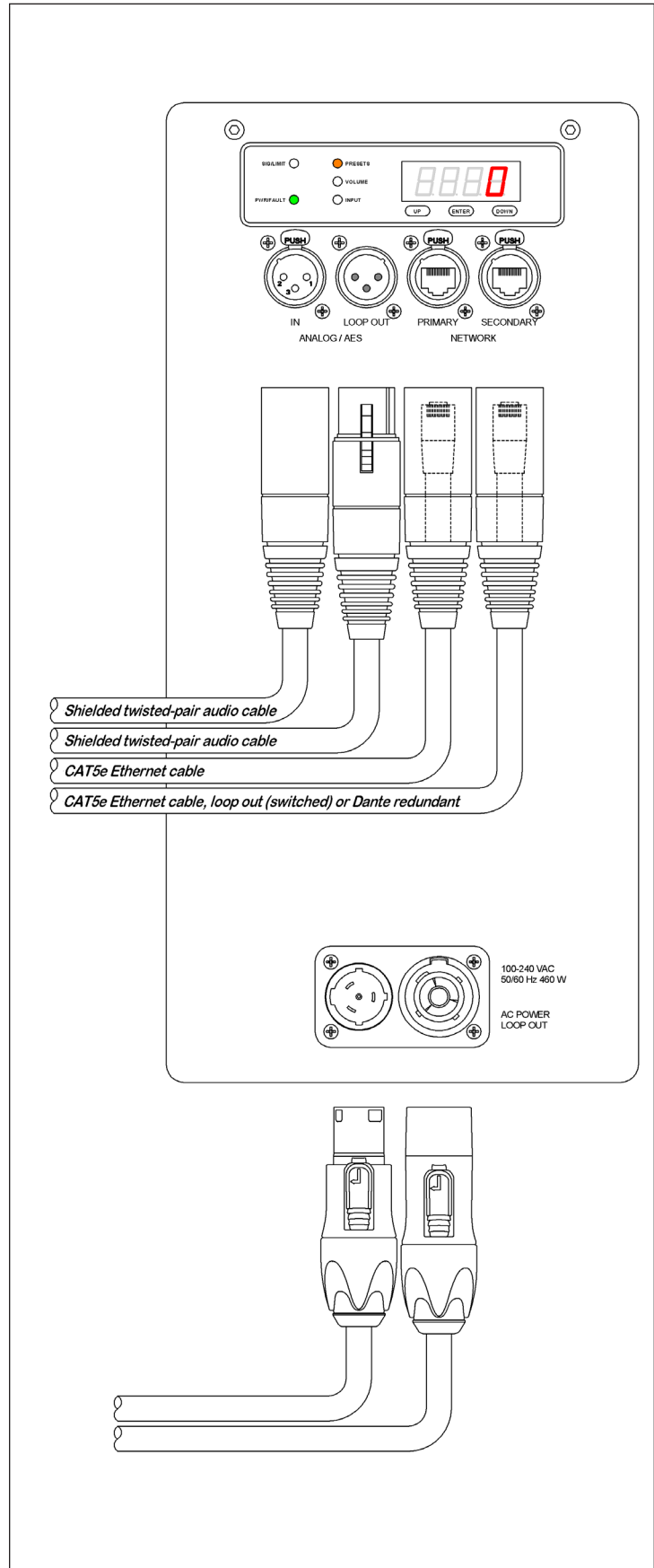

## Fixed Install Connections

All connections on the fixed install version are made inside the input pocket on the upper panel. Remove the pocket cover plate to access the connections. The pocket cover has a cable exit slot and should be reinstalled after the connections are made.

- Analog Inputs A1 and A2 on Phoenix pluggable terminal blocks, 3.5 mm pitch. Recommended wiring with Belden 1800F or equivalent 110 ohm digital audio cable. *Note, A1 and A2 are separate, selectable inputs, for looping, parallel at the terminal connections.*
- Fault Relay on a Phoenix pluggable terminal block, 3.5 mm pitch. The fault relay is a SPDT relay that changes state when a fault is detected with the amplifier. The normal state, i.e. normally open, fault closed or normally closed, fault open is selectable in RHAON II
- AES-3 digital audio input on a Phoenix pluggable terminal block, 3.5 mm pitch. Recommended wiring with Belden 1800F or equivalent 110 ohm digital audio cable.
- Ethernet/RHAON II connection on an RJ45 connector. CAT5e or CAT6 wiring.
- Reset Button: Push and hold for 3-5 seconds to reset unit to factory default settings. *Note, any user presets are saved, but working memory is cleared when a unit is reset.*
- AC Mains Power on Neutrik powerCON 20A connector. Input voltage 100-240 volts, 50/60 Hz., auto-switching.

For connections to other fixed version -RN cabinets in an array, see the array connections section on pg. 15.

## Dante -RD units

All connections for the -RD units are the same as the -RN units except for the Ethernet connections.

- Dante Primary and Secondary on RJ45 connections, CAT5e or CAT6 wiring.
- *Note, the Dante Secondary port can be used either as a switched, network “looping” connection, or as a redundant fail-over network connection. This is selectable in Dante Controller software.*

For connections to other fixed version -RD cabinets in an array, see the array connections section on pgs. 16 & 17.

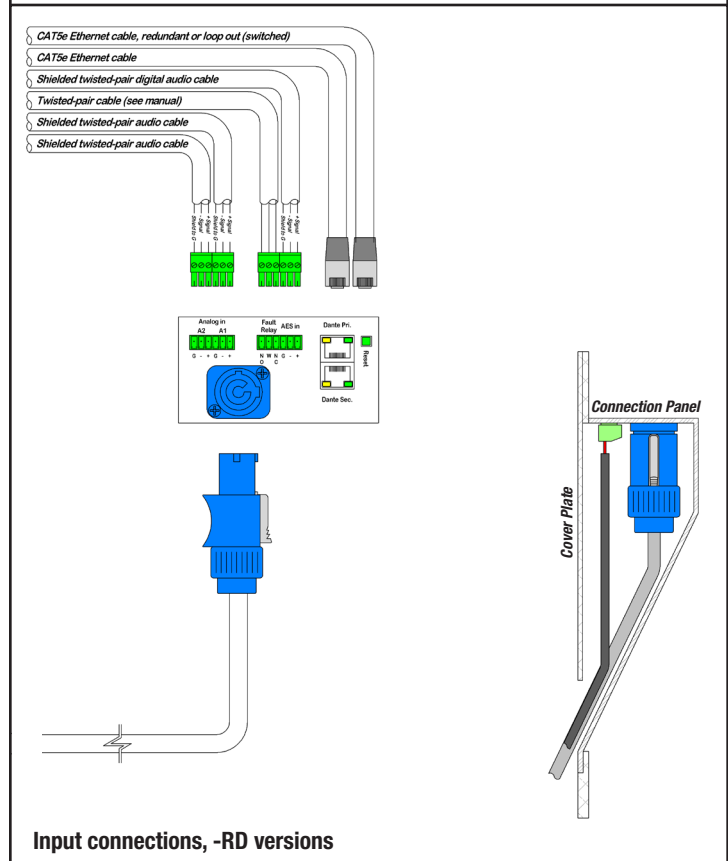
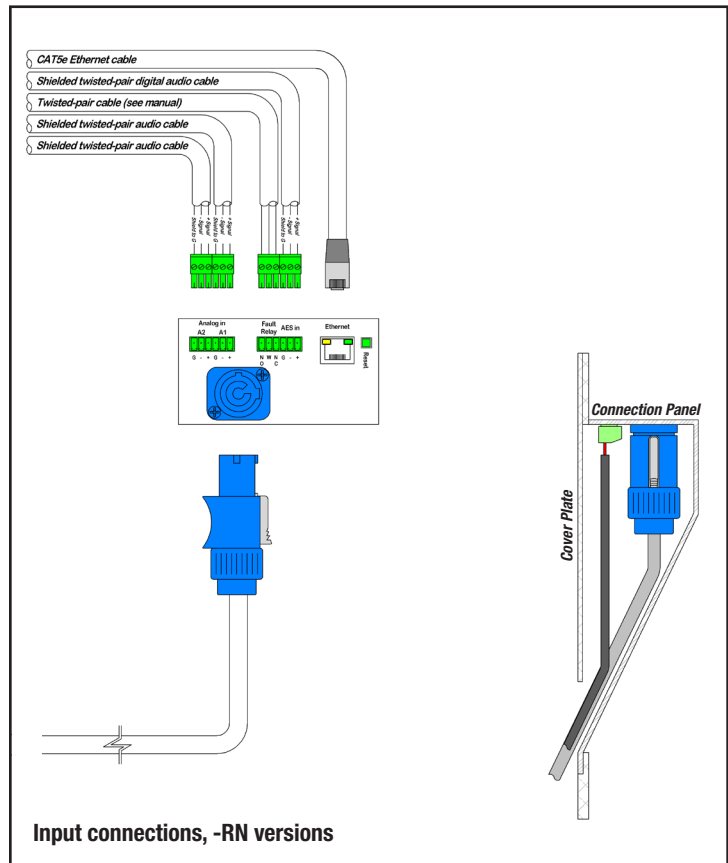



## Amplifier Control Panel

The control panel of the amplifier allows selection of the input, Analog, AES or Dante, recall of presets and control of the volume. It also has a signal present/limit indicator and power/fault indicator.

- SIG/LIMIT LED will show green to indicate signal present. Yellow indicates the onset of limiting, Red indicates full limiting.
- PWR/FAULT will show green to indicate that the unit is powered and on. Red indicates a fault has been detected and the amplifier is protecting itself from damage.

To use the controls and the multi-function LED display, press the ENTER button to select the desired function, PRESETS, VOLUME or INPUT as indicated by the amber LED. Then use the up and down buttons to select the desired function.

- Input Selection: Push ENTER until the amber LED next to INPUT is lit. Use the UP and DOWN buttons to scroll through AnA (Analog), AES 1, AES 2, dAn 1 (Dante 1) and dAn 2 (Dante 2) input selections. Press ENTER to confirm the selection. If no selection is made after 7-8 seconds, the display will return to the current input.
- Volume Control: Push ENTER until the amber LED next to VOLUME is lit. Use the UP and DOWN buttons to set the volume level in dB attenuation. 0 is all the way up, negative values indicate attenuation from full up. Volume is adjustable in ½ dB steps.
- Preset Selection: Push ENTER until the amber LED next to PRESETS is lit. Use the UP and DOWN buttons to scroll through stored presets. When the desired preset is displayed, press ENTER to recall the preset. LOAd will display while the preset loads. Note, user presets must be created and stored with RHAON II. If a preset is empty, the display will return to the currently loaded preset without showing LOAd.

All input, volume and preset selections are retained in non-volatile memory. The selections will remain at the selected values even if the power is turned off.

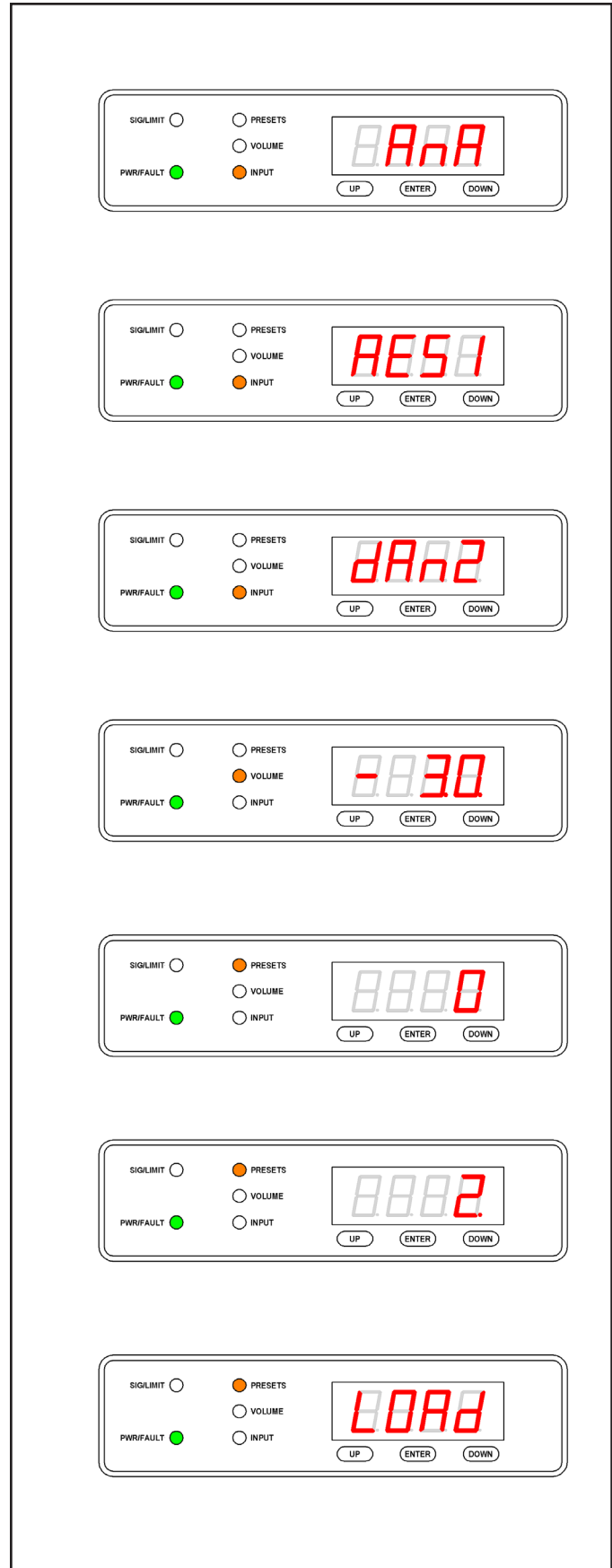

## Array Assembly

ICLive X, ICLive XL, and ICLive LX modules are shipped individually. Arrays of multiple cabinets are assembled using the array hardware on the loudspeakers.

Every ICLive X series cabinet has array bars on each side and the back. When building arrays these bars pin together with three quick-release (QR) pins. The QR pins are tethered to the cabinets with short leashes.

The same QR pins are used to attach the RHANG-ICLX flybar and the ICLX-GSA ground stack adaptor plate. The ICLX-GSA is used to attach ICLive X arrays to associated Renkus-Heinz subwoofers.

To build an arrays of ICLX, ICLXL or ICLLX cabinets:

1. Remove the QR pins from the top of the bottom cabinet in the array and allow them to hang from their lanyards.
2. Stack the second module on top of the first, aligning the three tabs on the top of the lower unit with the three slots on the bottom of the upper unit.
3. Insert the three quick-release pins into the holes in the array bars.
4. **Important! Pull back on the pins to insure that they are securely locked into place.**
5. Repeat with all of the cabinets in the array.
6. The RHANG-ICLX flybar attaches in the same manner to the top cabinet in the array. Align the tabs with the slots and pin in place with the QR pins.
7. **Important! Pull back on the pins to insure that they are securely locked into place.**

If you are building a tall array that will be flown, it may be easiest to start with the top cabinet and install the RHANG-ICLX flybar. Then lift the first cabinet and slide the successive cabinets into place pinning with the QR pins as the array is built from the top down.

***WARNING! Flying or suspending loudspeakers is a serious undertaking that should be done only by qualified and experienced personnel. Check with an Architect or Structural Engineer to verify any building attachment points. Renkus-Heinz is not responsible for any non-Renkus-Heinz products or for any misuse of Renkus-Heinz products.***

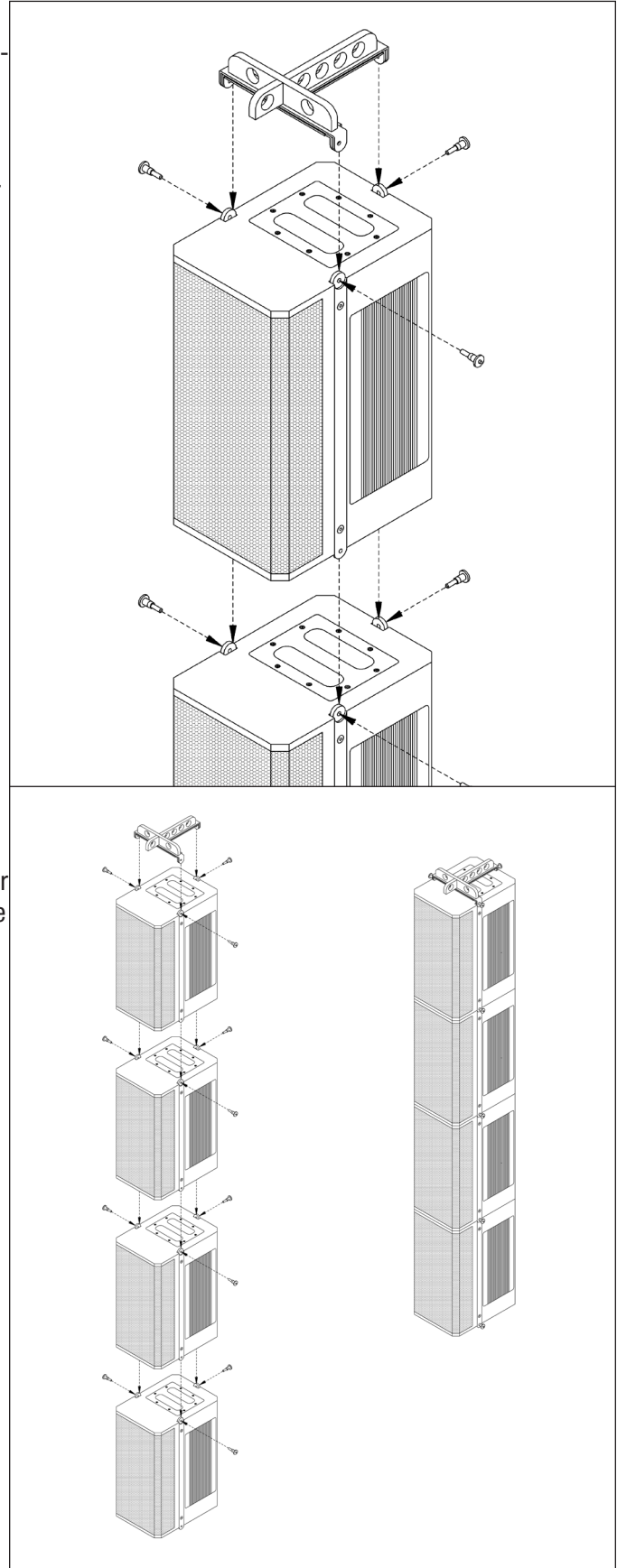

## Ground Stacking

ICLive X series is ideally suited to portable applications. Each ICLX and ICLXL module has a tripod socket on the bottom of the cabinet. A single ICLXL or two ICLXs can be supported by a standard loudspeaker tripod stand.

In addition, Renkus-Heinz subwoofers are equipped with a 20 mm threaded socket into which threads POLE-101, allowing the subwoofer to be the base for an ICLXL or two ICLXs. *Never put more than one ICLXL or two ICLXs on a tripod stand or POLE-101.*

For taller arrays supported on subwoofers the ICLX-GSA ground stack adaptor plate is available.

The ICLX-GSA attaches to the subwoofer with a hand screw using the 20 mm threaded socket. The large, single point of attachment allows for horizontal aiming of the array without turning the subwoofer.

1. Attach the ICLX-GSA to the subwoofer with the hand screw and tighten securely.
2. Remove the QR pins from the ICLX-GSA and splay them out so that they do not become trapped under the ICLive array.
3. Set the first cabinet in the array into the ICLX-GSA, aligning the slots in the cabinet with the tabs in the ICLX-GSA.

4. Insert the three QR pins into the holes in the array bars.
5. **Important! Pull back on the pins to insure that they are securely locked into place.**
6. Repeat with all of the cabinets in the array.

***Warning! To avoid toppling, never stack more than two ICLX modules or one ICLXL on an SA112 subwoofer, or subwoofer of similar size. Never stack more than four ICLX modules or any combination of equivalent height on an SA118 subwoofer, or subwoofer of similar size.***

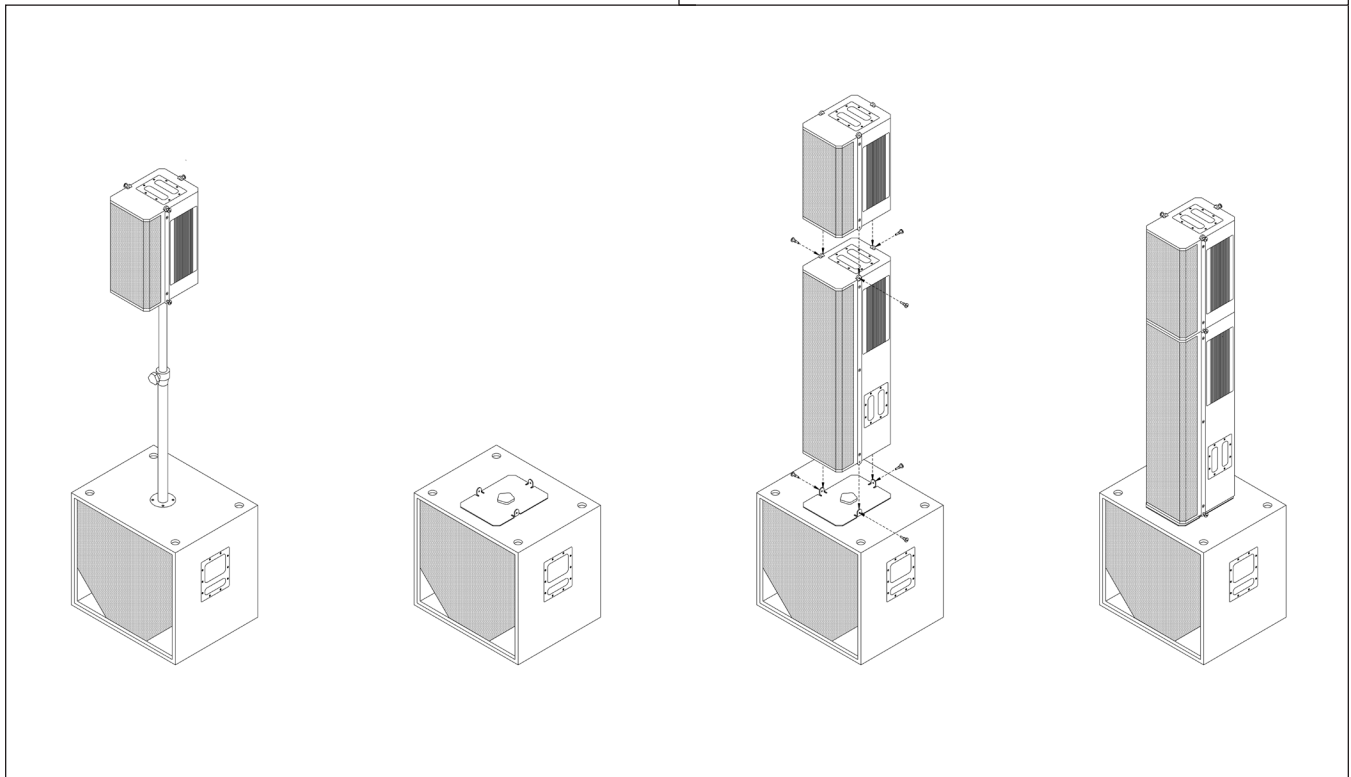
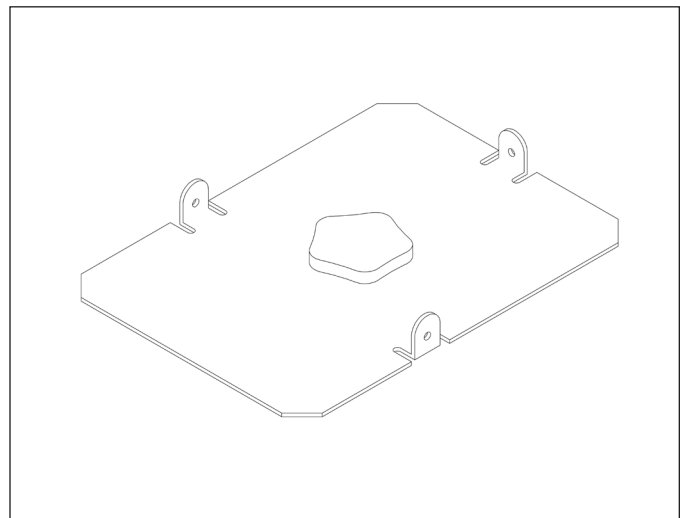

## Hinge Kit Brackets

Install versions of the ICLive X series can be mounted to a wall with a hinge kit mounting system. The hinges are pintle and gudgeon separable hinges. The male, pintle, half mounts to the wall or other supporting structure, the female, gudgeon, half mounts to the loudspeaker cabinet.

Once the pintle halves are mounted to the supporting structure, the loudspeaker mounts by sliding the gudgeon over the pintle. The loudspeaker can be aimed horizontally through a 75 degree arc. The pintles can be installed on either side of the hinge wall brackets, allowing the ICLive X array to aim to either side. When the desired aiming is achieved, the lock-angle rod on the bottom hinge is used to secure the aiming.

ICLive X Hinges are sold under two part numbers:

- HK-ICLX: Includes two hinges, the minimum needed to wall mount an ICLive X Array.
- HK-ICLX-1: Single additional hinges for installing larger ICLive X Arrays.

The hinges are shown in red in the accompanying drawings.

## Hinge Kit Guidelines and Instructions

- The maximum number of cabinets in an array that will be supported by the hinges is six ICLX or a combination of ICLX and ICLXL/ICLLX of equivalent height. An array taller than the equivalent of six ICLive X, will require the use of RHANG fly-bars.
- The minimum number of hinges to mount a single cabinet is two. For multi-cabinet arrays, the number of hinges should equal the number of cabinets in the array. (ICLXL-ICLLX arrays require three hinges.) The hinge position at the top or bottom of any individual cabinet in the array may be used to accommodate local mounting needs. Always use a hinge at the bottom of the array for the lock-angle rod.
- The hinges will be packaged separately from the loudspeaker cabinets. Once you have determined the locations on the cabinets where the hinges will be used, remove the three M6 bolts from the back of the loudspeaker, just above or below the amplifier.
- Place the hinge plate with the female gudgeons in place with the openings facing down.
- Reinstall the 6 mm bolts using thread locking compound and tighten securely.

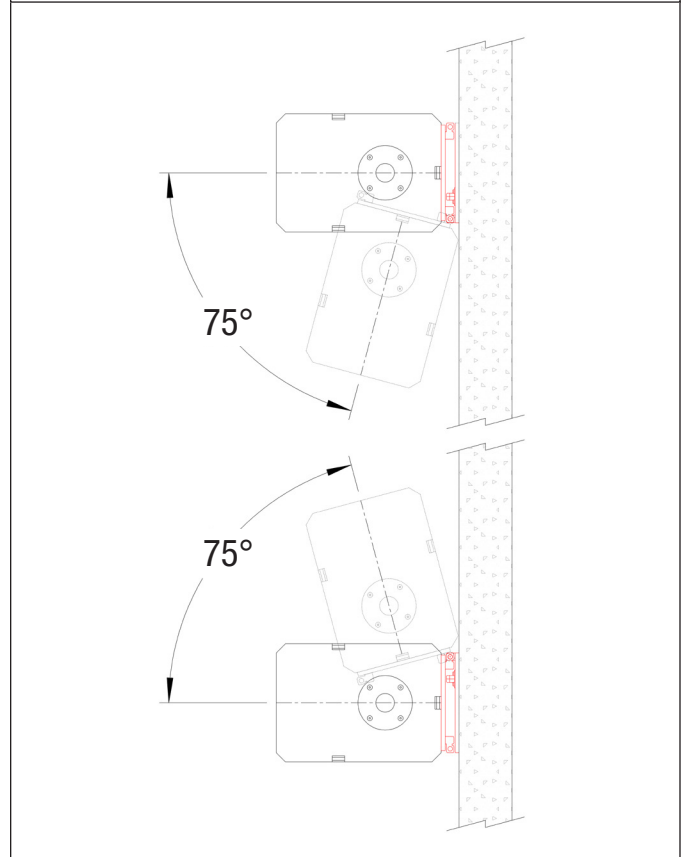
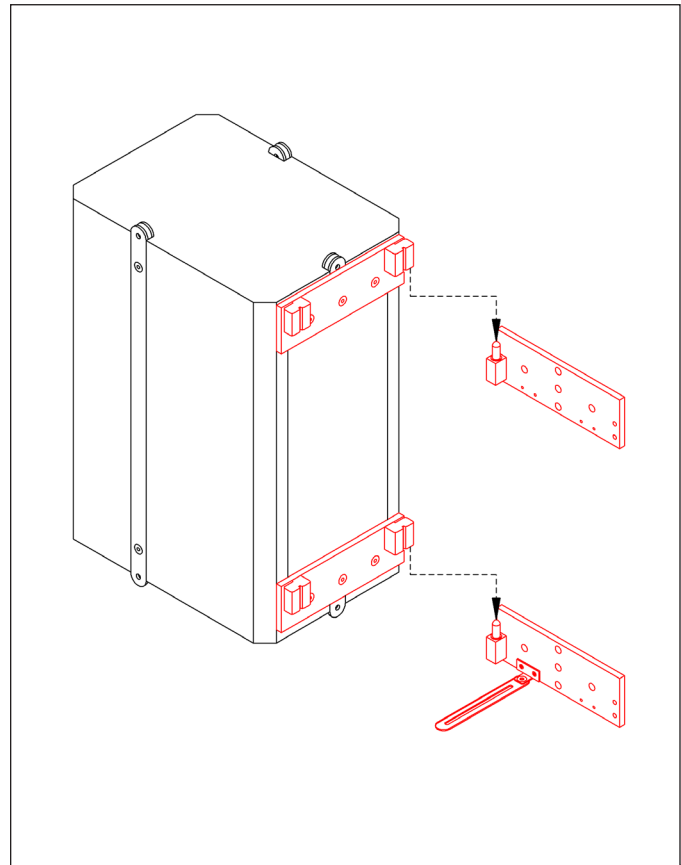

## Wall Mounting

- As the installer you must insure that the wall or other mounting surface is capable of safely supporting the weight of the array.
- Use fasteners appropriate to the mounting surface, for example, ¼ inch or 6 mm lag bolts into wooden studs or similarly sized concrete anchors for masonry walls.
- ICLive X arrays are too heavy to be supported by gypsum wall board alone, you must anchor the brackets to structure.
- Mark and install the pintle halves of the hinges to the wall or other mounting surface with the pins facing up.
- A good way to mark the locations of the hinge brackets on the wall is to use a “story stick.”
  1. Assemble the array as instructed on page 10.
  2. Install the hinges on the loudspeakers at the desired locations.
  3. Cut a length of board—a 1 x 4 works well—to the length of the assembled array.
  4. Hold the board up to the array and mark the locations of the hinges.
  5. Use the “story stick” to transfer the locations to the wall or other mounting surface.
- Lift the array onto the pintle hinges.
- Set and secure the aiming with the lock-angle rod.

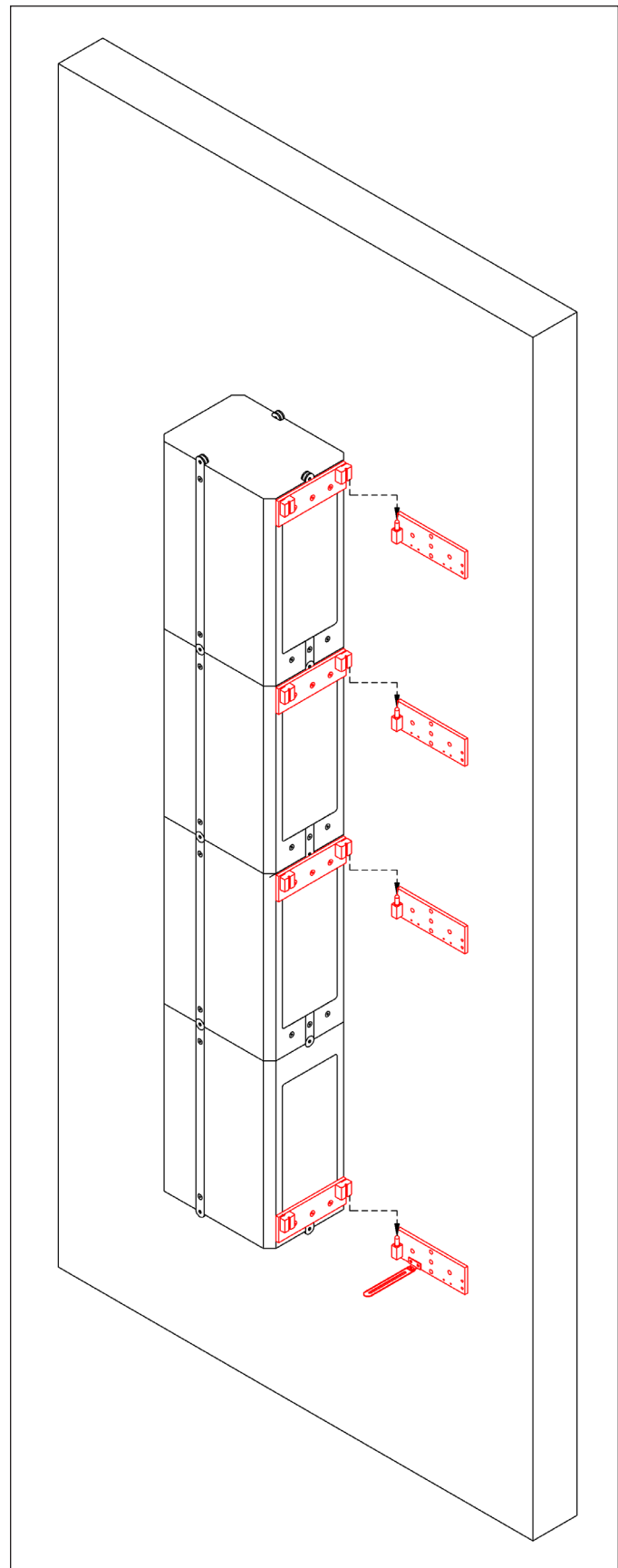

**WARNING! Flying or suspending loudspeakers is a serious undertaking that should be done only by qualified and experienced personnel. Check with an Architect or Structural Engineer to verify any building attachment points. Renkus-Heinz is not responsible for any non-Renkus-Heinz products or for any misuse of Renkus-Heinz products.**

### Array Interconnections

ICLive X modules connect to each other to form a single array for Beam steering. Three connections are required, AC mains power, Audio and Data. On the Dante-equipped units, the audio and data are both carried on the Ethernet data connection. The following diagrams show how to interconnect the arrays. In all of the diagrams AC mains power is shown in red, audio is shown in blue and Ethernet is shown in green.

### Mobile Unit Interconnections

For the mobile versions of ICLive X series, looping cables assembled to the correct lengths are available from Renkus-Heinz.

- Audio Looping: The CBL-ICLX-XLR cable provides analog or AES signal looping.
- Ethernet Looping: The CBL-ICLX-DLK cable loops RHAON data and Dante Audio (if equipped).
- Power Looping: The CBL-ICLX-PWRLK loops AC Mains power

Renkus-Heinz also offers looping cables to integrate ICLive X arrays with the ICLX-118S Subwoofers:

- CBL-XLR-L1: XLR audio looping for Subwoofer to Subwoofer, or Subwoofer to ICLX
- CBL-XLR-L2: XLR looping for Subwoofer to ICLXL
- CBL-DLK-L1: Ethercon looping for Subwoofer to Subwoofer, or Subwoofer to ICLX
- CBL-DLK-L2: Ethercon looping for Subwoofer to ICLXL
- CBL-PWRLK-L1: powerCON True1 looping for Subwoofer to Subwoofer, or Subwoofer to ICLX, or Subwoofer to ICLXL

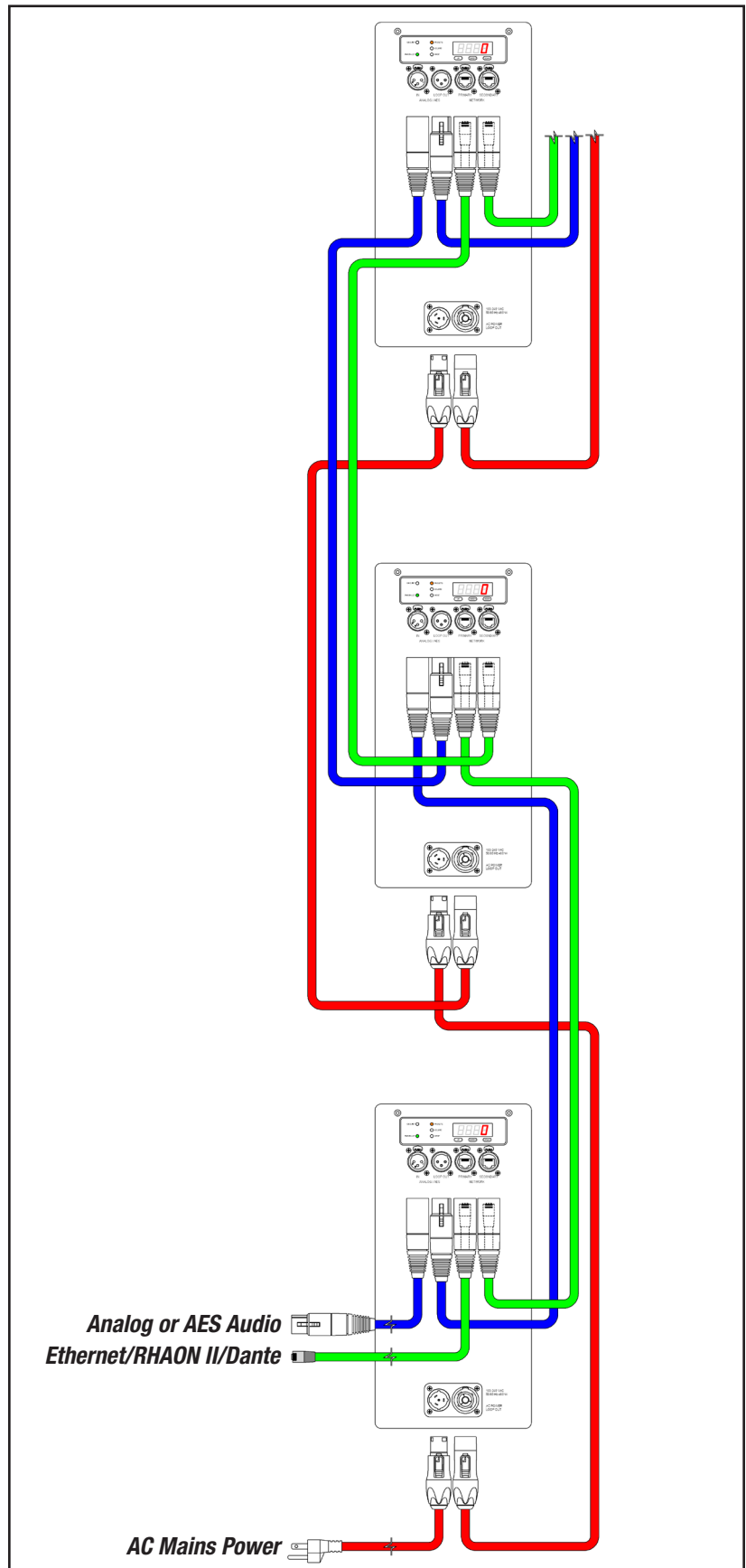



### Fixed Install Interconnections

The fixed install versions require the same interconnections, but they are implemented on different connectors optimized for permanent installation.

#### Interconnecting -RN units

- Analog, or AES signal can be looped by paralleling the wires at the Phoenix terminals.
- AC mains power looping is not available, each cabinet in an array must have its own power cable.
- Ethernet cannot be looped when using -RN, RHAON only, units, a star network topology is required with each unit in the array home run to a switch.

This connection topology offers the greatest reliability, if any cabinet fails, audio, power and data are not interrupted to any of the other units in the array.

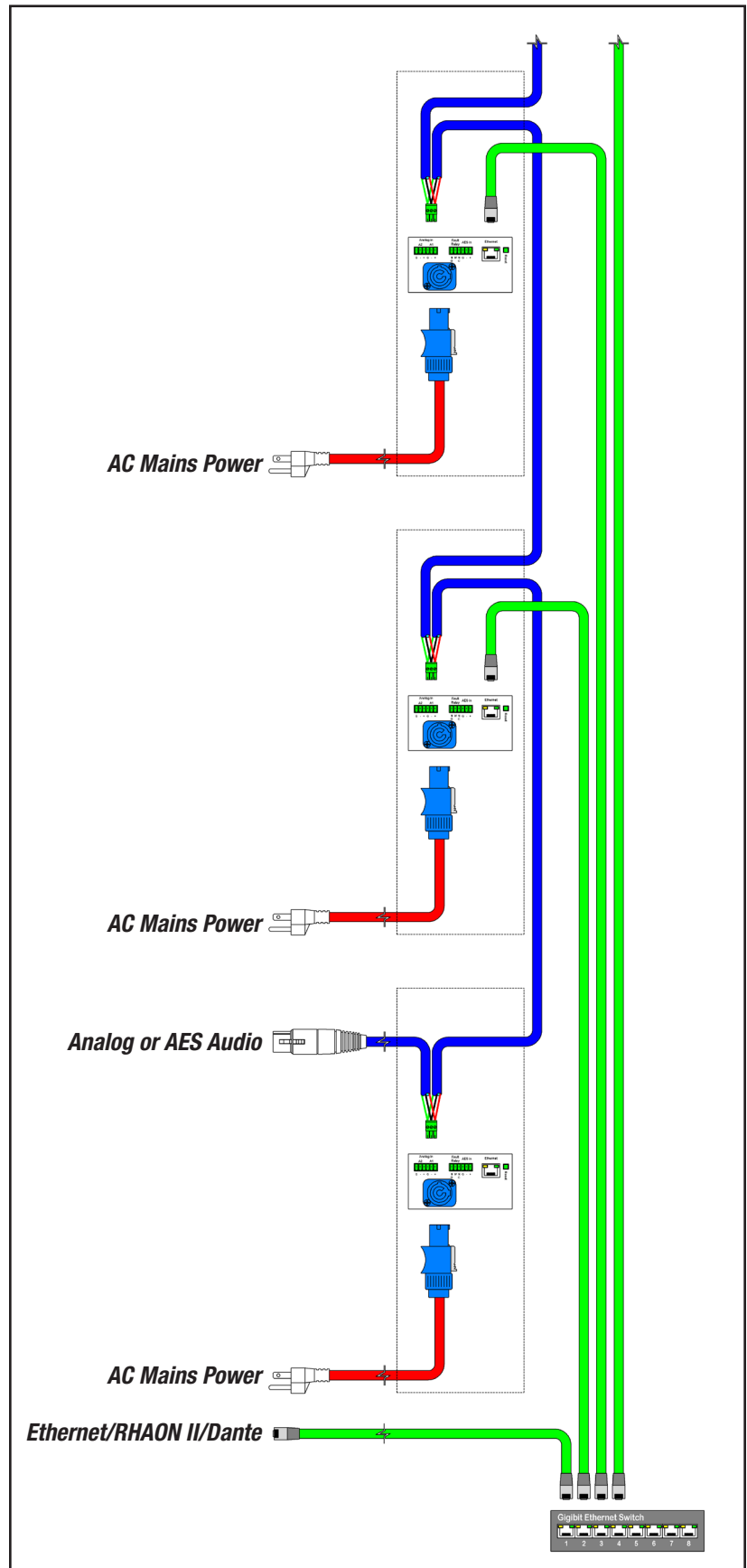

## Fixed Install Interconnections, continued

### Interconnecting -RD units

- Analog or AES signal (if desired) can be looped by paralleling the wires at the Phoenix terminals. (Note, not shown on diagram, see -RN diagram for Analog/AES looping)
- AC mains power looping is not available, each cabinet in an array must have its own power cable.
- Ethernet/Dante can be looped by utilizing the Dante Secondary port as a “Loop Out.” In this application the Dante ports act as a two-port gigabit switch. Each looping connection will count as a switch hop for Dante latency. Renkus-Heinz recommends only looping within a single array, connect arrays in a star configuration to the network switch. ICLive X units are shipped with the Dante ports in switched mode.

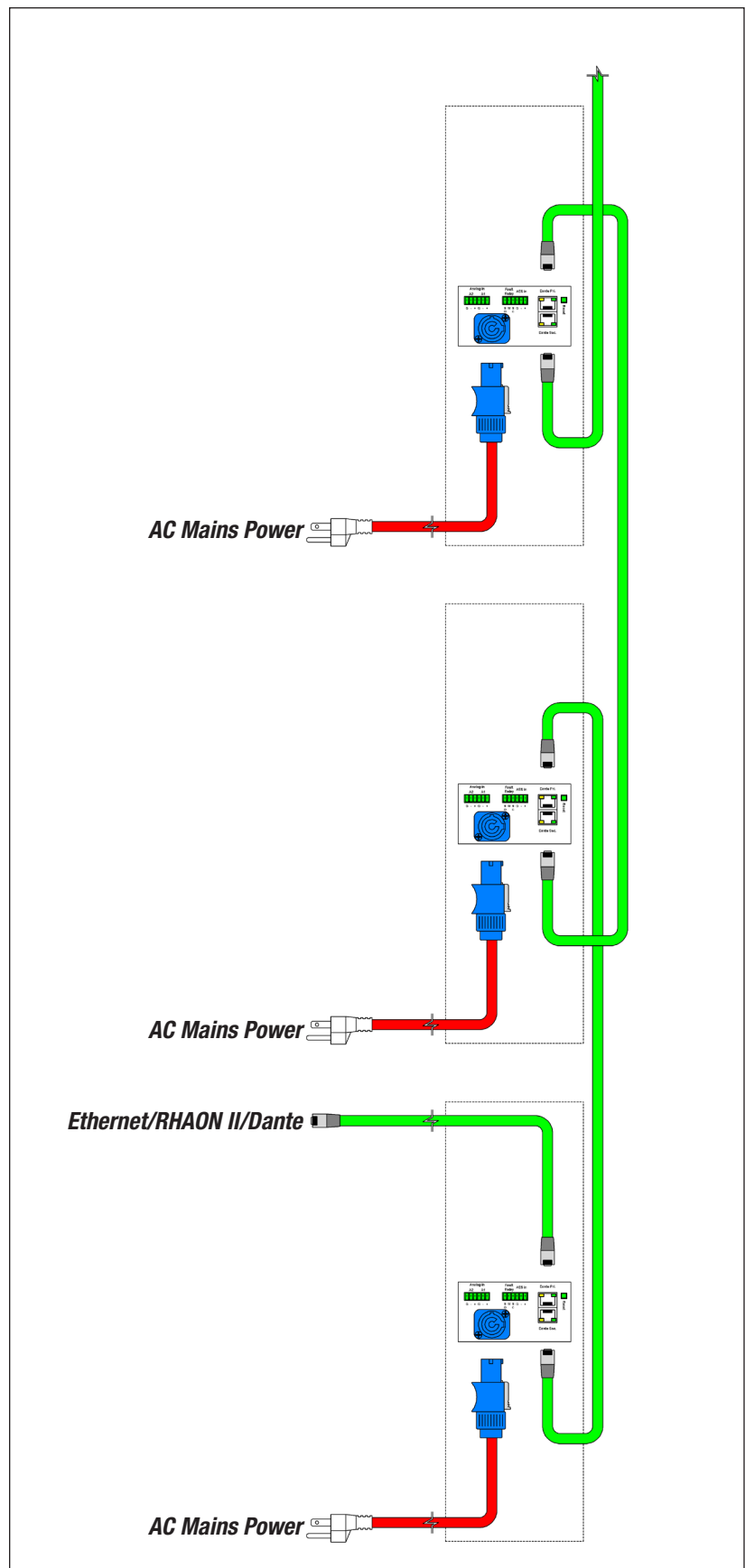

**Fixed Install Interconnections, continued**

**Interconnecting -RD units with a redundant network**

The Dante units can be configured for redundant networking. Two completely separate Ethernet networks are installed in parallel. Network redundancy is only achieved with separate physical networks. Implementations using two V-LANS achieve only cable redundancy.

Setting the units for redundant networking is done in Dante Controller. ICLive X units are shipped with the Dante ports in switched mode, if redundant networking is desired the switch must be made using Dante Controller. Connections are similar to the -RN units, but the network connections are doubled.

- Analog or AES signal (if desired) can be looped by paralleling the wires at the Phoenix terminals. (Note, not shown on diagram, see -RN diagram for Analog/AES looping)
- AC mains power looping is not available, each cabinet in an array must have its own power cable.
- Ethernet/Dante must be connected in a star configuration to a network switch. The redundant network is connected to the secondary port.
- If the Dante carrier is lost on the primary network connection, the unit will switch to the secondary network, normally with no loss of data or any audible artifacts.

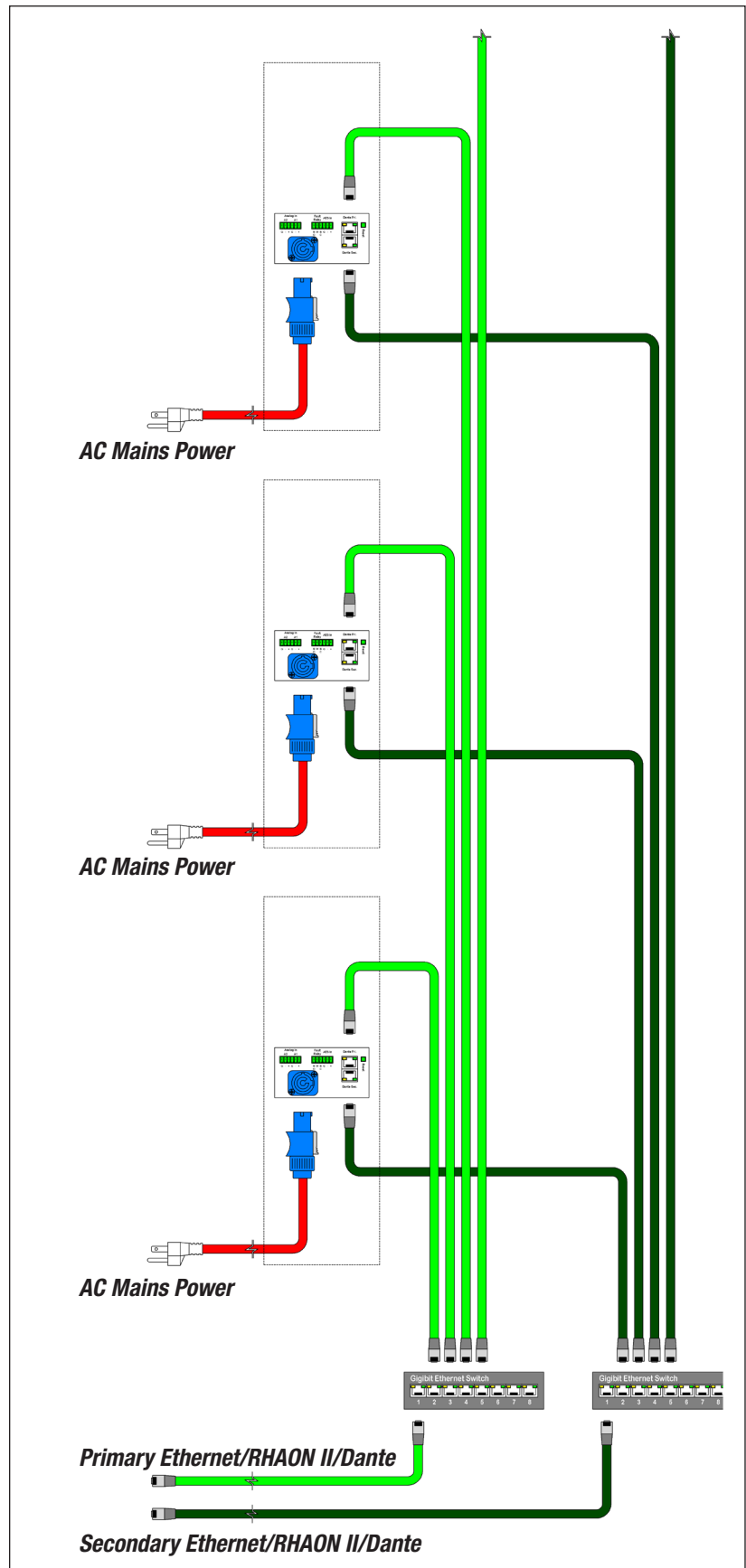

## Designing and Beam steering ICLive X Arrays

The ICLive X series offers the system designer tremendous flexibility in array design, balancing directivity, output and cost. Here we'll cover the basics of the decisions involved in designing an ICLive X array. For a full discussion of the science of beam steering and steerable line arrays, please refer to the Iconyx Certification materials.

Three basic factors must be considered when designing an ICLive X array.

1. Directivity and steering; taller arrays are more directional and can effectively steer to a lower frequency. Greater directivity also equates to increased intelligibility in reverberant environments.
2. Output; taller arrays composed of all ICLX cabinets have more output capability than shorter arrays. Doubling the number of ICLX cabinets in an array will increase maximum output by 3 dB.
3. Cost; if cost were no object, all arrays would be built with ICLX modules, but cost is always a concern. The ICLXL and ICLLX cabinets allow the designer to increase the length of an array in two-unit increments, at the expense of maximum output.

### Array Guidelines

When designing, or assembling ICLive X arrays, the following guidelines must be followed:

- ICLX modules can be arrayed up to 12 units tall. Arrays of more than six units tall must be flown, not mounted on the hinges.
- Arrays using ICLive XL or ICLive LX modules are limited to the equivalent array length of a six unit tall array of ICLXs. *If you have a project that you feel needs a longer combination please contact the factory for additional support.*
- ICLLX Cabinets can ONLY be used at the top of an array.
- ICLXL Cabinets can ONLY be used at the bottom of an array.

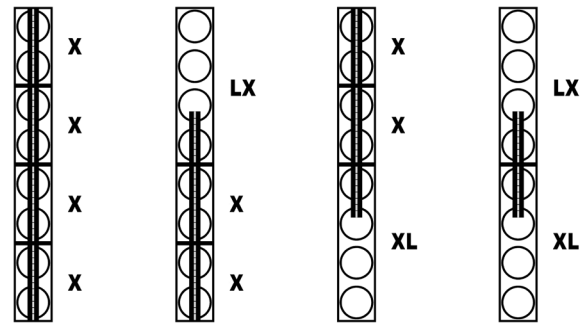

Array	X-X-X-X	X-X-LX	XL-X-X	XL-LX
SPL Output	Best	-3 dB	-3 dB	-6 dB
Steer Frequency	375 Hz.	375 Hz.	375 Hz.	375 Hz.
HF Array Location	Entire	Lower ¾	Upper ¾	Middle ¾
No. HF Drivers	24	16	16	8
No. Amp Channels	32	24	24	16
Total Amp Power	4 kW	3 kW	3 kW	2 kW
Cost	Highest	Mid	Mid	Lowest

- ICLX Cabinets can be installed ABOVE an ICLXL, or BELOW an ICLLX.

These rules ensure that combinations of ICLX, ICLXL, and ICLLX, the HF Horn assemblies for a continuous line.

Remember, the tallest array possible when using either the ICLXL or ICLLX is the equivalent of six ICLX units tall.

A final consideration is the location of the high frequency section when using the ICLXL and ICLLX modules.

If the array is mounted fairly low, 6-10 ft./2-3 m from the bottom of the array to the finish floor, keeping the HF section at the top of the array is generally preferred. If the array is mounted higher, having the HF section in the lower part of the array is often an advantage.

The chart and graphic above illustrate the four ways a designer can create a four-unit tall array, with the advantages and compromises listed.

## RHAON & Beam steering Workflow

The ICLive X Series is controlled and beam steered with RHAON II software. The following instructions assume an understanding of RHAON II software and beam steering workflows. If you are unfamiliar with RHAON II, the user manual is accessible from the RHAON II Help menu.

Unlike other Iconyx models, which build arrays of master and slave units, ICLive X arrays are all master, every loudspeaker is addressed individually in the software. In order to control and beam steer an array of multiple ICLive X loudspeakers, they are grouped in RHAON II.

RHAON II offers two different group types, “Device Groups” for group processing traditional point-source, line-array, and subwoofer systems; and “Array Groups.” Array groups allow controlling, steering, and monitoring an “ICLive X Array” as a single entity. IC Live X arrays must be grouped in order to beam steer them.

- To create an array group of ICLive X loudspeakers, first identify and name the loudspeakers in each array. The blue wink LED’s on the front of the loudspeaker can be switched on in RHAON II to identify individual loudspeakers. *See image 1.*
- When naming individual loudspeakers in an array, we recommend an alpha-numeric name, where the numbers ascend in order from the bottom of the array to the top; meaning the bottom most box should be named XXX-1, the next one up would be XXX-2, and so on. ICLive X array groups must be built from bottom to the top in RHAON II. *See image 2.*
- Once the individual loudspeakers in each array have been identified and named build the ICLive X array group.
  1. Create an ICLive X Array Group in the Groups Pane. *See image 2.*
  2. Starting with the bottom loudspeaker in the array, add the individual loudspeakers from the Devices Pane, to the new ICLive X Array Group. *See image 3.*
  3. If necessary, reorder the devices in the array to match the physical array.
  4. Name the ICLive X Array Group
  5. Add the Array Group to the active Zone. *See image 4.*
  6. Repeat for any additional arrays in the system.

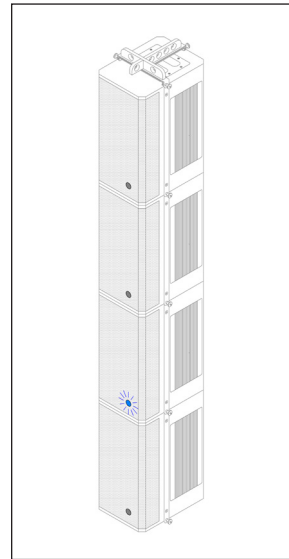

Image 1



Image 2

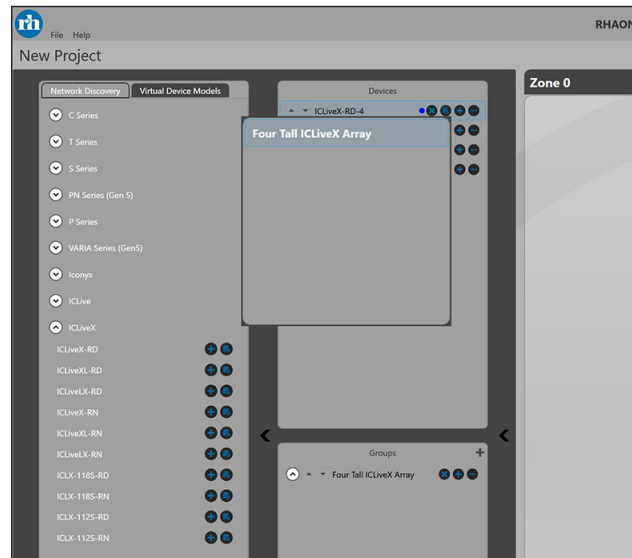

Image 3

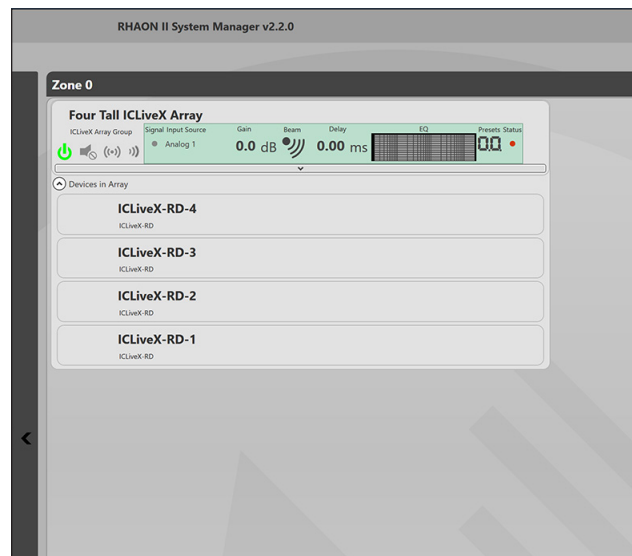
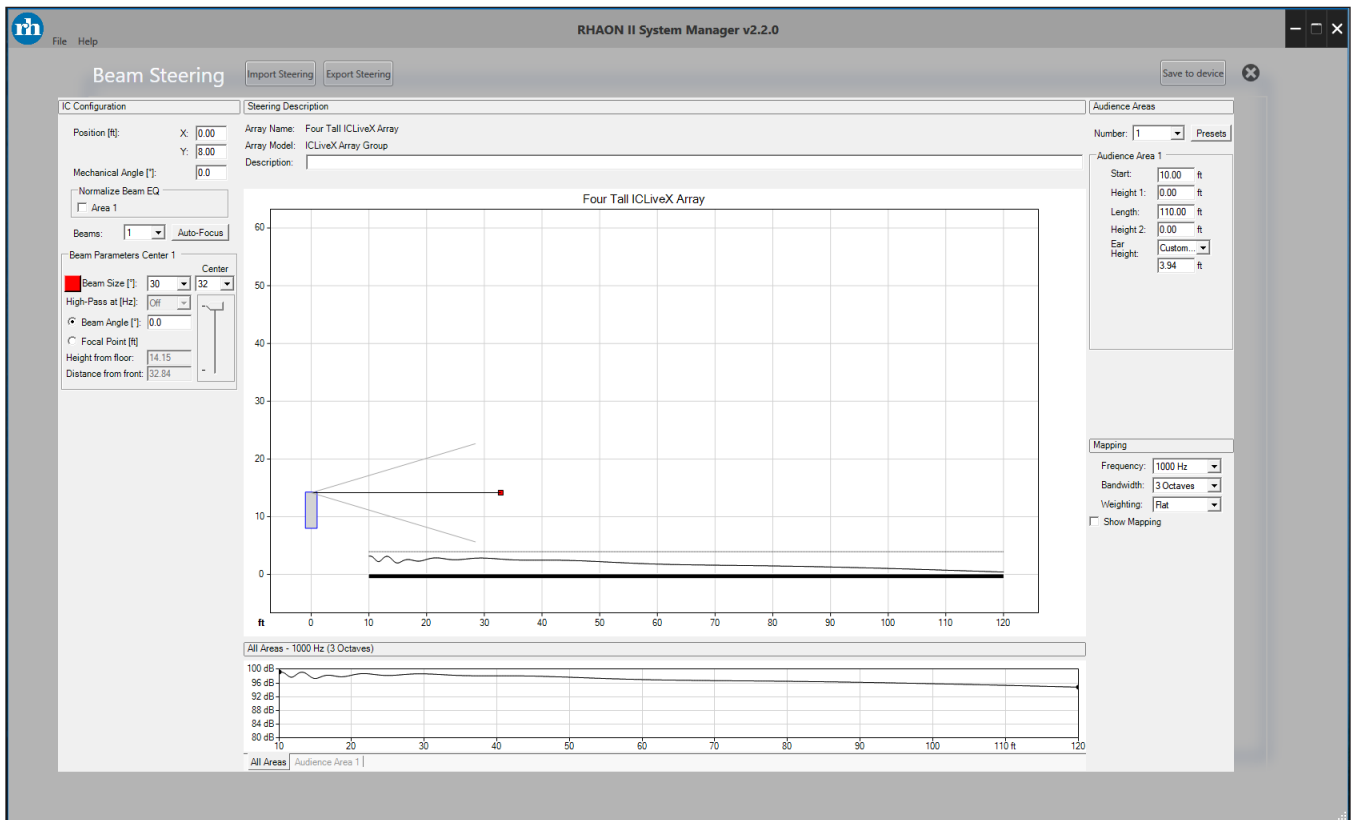

Image 4



## ICLive X Beam steering

Once added to the Active Zone single ICLive X loudspeakers or Array Groups can be beam steered.

To begin beam steering, click on the Beam icon in the control panel for the loudspeaker or array to be steered. The Beam Steering window will open.

Enter the room parameters for simulation.

- On the left, enter the X and Y coordinates for the array. The Y coordinate is the distance from the finish floor to the **bottom** of the array. The X coordinate is normally left at 0, but can be set to other references if needed.
- Audience area coordinates are entered referenced to the finish floor level. The ear height simulation plane is then added automatically. The ear height is selectable

for seated or standing audiences, or a custom value can be entered if desired.

## U.R.G.O Beam Steering

The ICLive X Series uses a new beam-steering algorithm developed specifically for it called U.R.G.O for UniBeam Room Geometry Optimization.

U.R.G.O. simplifies the beam steering process, and delivers consistent results with a simplified workflow.

U.R.G.O. technology creates an asymmetrical lobe of coverage based on the opening angle required for optimal coverage. These opening angles are based on standard mounting heights for Iconyx and IC-Live loudspeakers, taken from over a decade of experience with steerable sound systems.



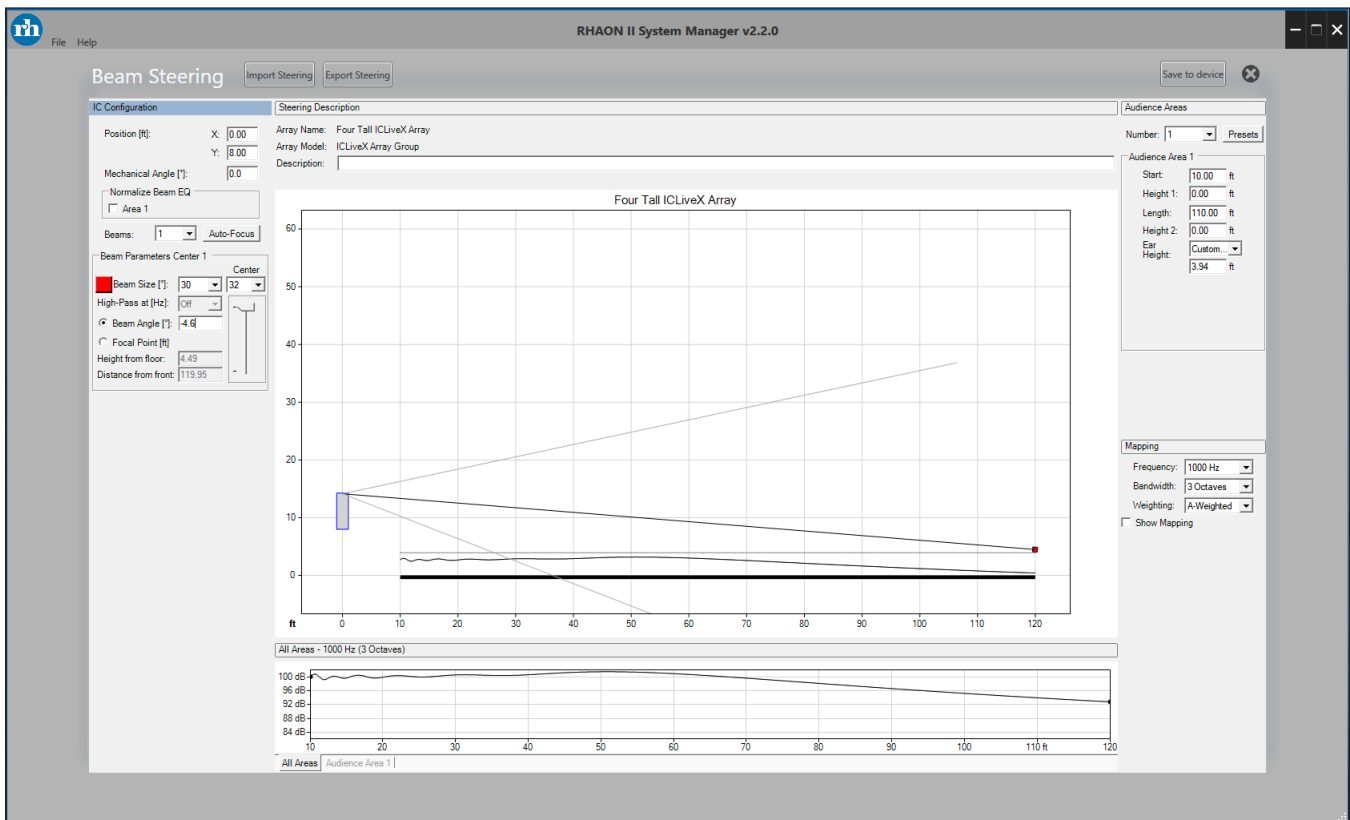

## U.R.G.O. Workflow

Once the simulation parameters have been entered the U.R.G.O. workflow is as follows.

1. Using the beam aiming handle, find the angle of inclination from the top of the HF array to the back of the room. Just grab the red handle and drag it to

the end of the audience area at ear height. Be sure to aim at ear height, not the floor level.

2. Read the angle in the Beam Parameters pane on the left side of the Beam Steering window. In the example above, the angle is  $-4.6$  degrees.
3. Make a note of this angle.

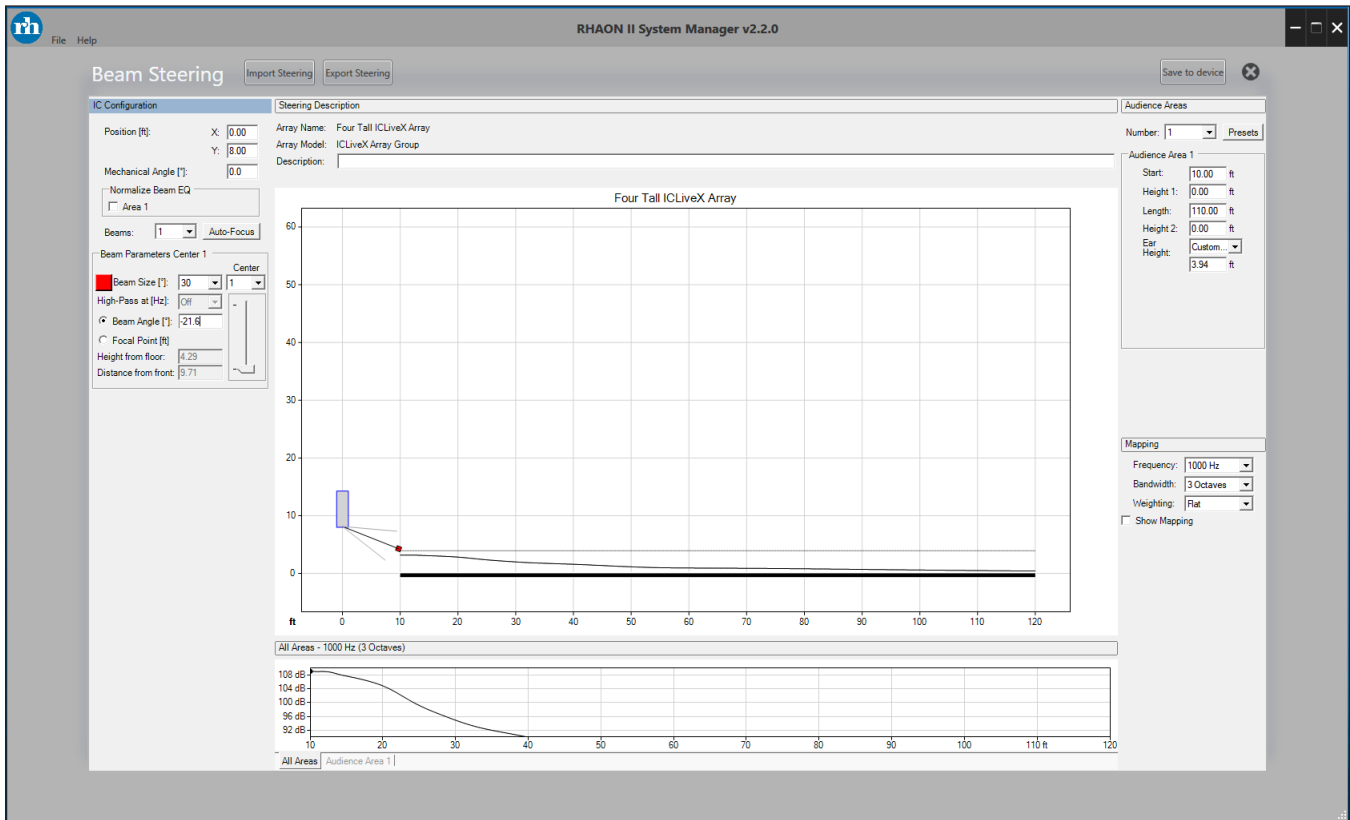

4. Next, move the beam center to the bottom position. Find the angle of inclination from the bottom of the HF array to the front of the audience area. As in the step above, drag the beam handle to the front of the audience area at ear height and read the angle in the Beam Parameters panel.
5. Make a note of the angle, in this case -21.6 degrees.
6. Find the difference between the “Top to Back” angle and “Bottom to Front” angle. In our example 21.6 – 4.6 degrees is 17 degrees.
7. Select the beam size with the closest matching angle, for our example a beam angle of 15 degrees.
8. Using the aiming handle, aim the beam at ear height at the back of the audience area.
9. Repeat these steps and add additional beams for each audience area in your project.
10. This process works for flat, and raked plane seating areas.

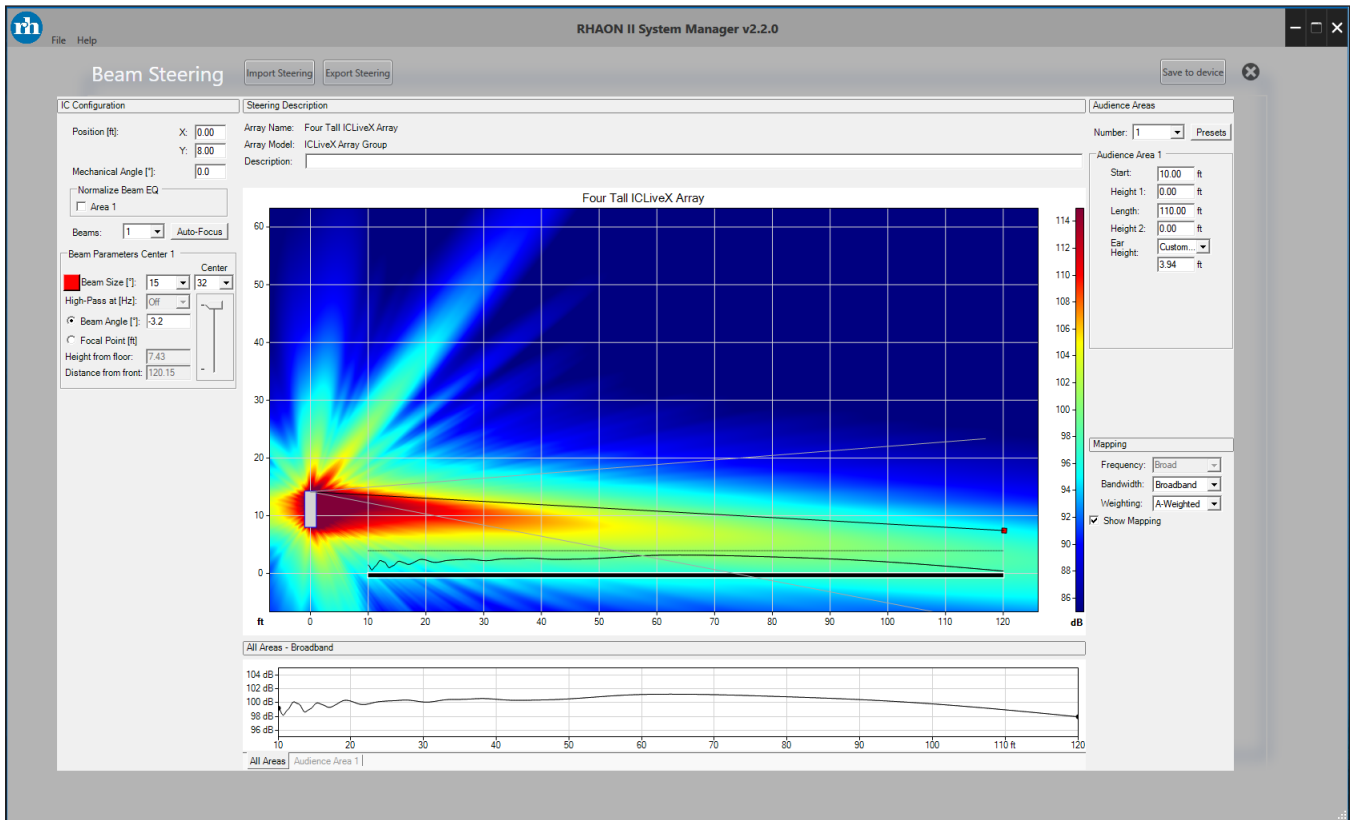

As can be seen in the results mapping above—a variation of + or -1.5 dB from front to back in a 120 ft./36 meter deep room—the U.R.G.O. workflow and beam results in excellent front to back coverage with minimal work.

### U.R.G.O. Refinements

U.R.G.O. beams are simple, but there are still some adjustments and tweaks that can further refine the coverage to the specific venue. U.R.G.O. beams have two acoustic centers, the Top, and the Bottom of the High Frequency Array.

The Top acoustic center, which allows greater down angles

of inclination, will often reduce reflections off side and rear surfaces. Additionally, the Top acoustic center can be used in an effort to increase gain before feedback with close proximity microphones.

The Bottom acoustic center will produce shallower angles of inclination, reducing the steering needed to achieve coverage, resulting in coverage to greater distances. The Bottom acoustic center can also be used to achieve greater front fill coverage. The single beam workflow that U.R.G.O. provides makes experimentation easy.



19201 Cook Street, Foothill Ranch, CA USA

Phone: +1 949 588 9997 • Fax: +1 949 588 9514

sales@renkus-heinz.com • www.renkus-heinz.com